

Energy saving with flow control of heat source pumps for air-conditioning systems

# Flow Control System for Refrigeration Machine Pumps

## Feature

- Attained the energy saving of heat sources for air-conditioning systems at an unprecedented level as well as the inverter control of refrigeration machine pumps.
- Reduces the power consumption of refrigeration machine pumps by 60%, thus saving a power of 390 MWh/year consumed by a semiconductor factory that uses four 210RT chillers.
- Received the Excellent Energy-saving Equipment Commendation from the Japan Machinery Federation.

## Overview

(Technical principles, actions, etc.)

A conventional refrigeration machine pump for heat sources used for air-conditioning systems involves a redundant bypass flow in a bypass pipe connected to the pump, because the pump is under constant flow control. DAI-DAN's Flow Smart uses a dedicated controller and inverter to reduce the bypass flow to zero, thus making it possible to realize optimum flow control according to each load. The Flow Smart performs the total control of primary (cold/hot water and cooling water) and secondary pumps.

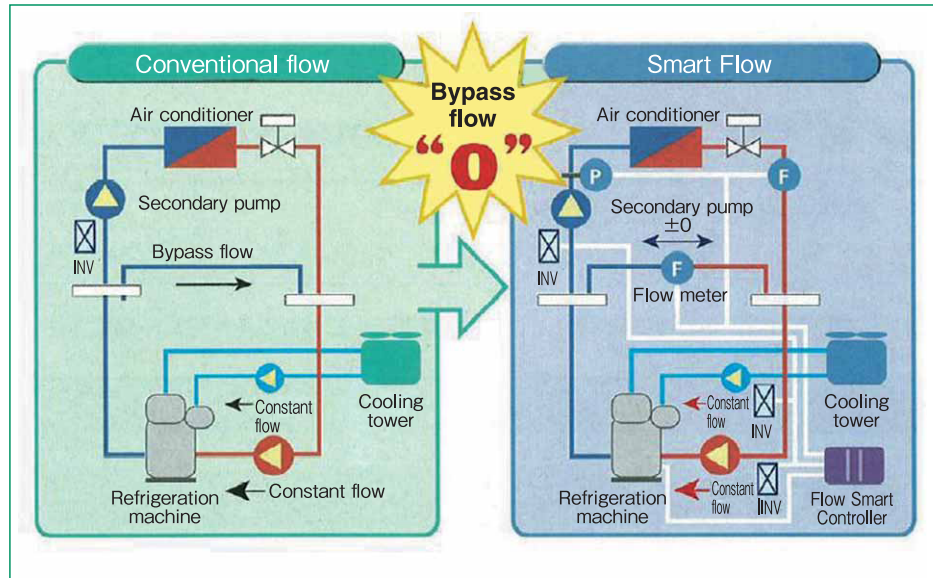

Operation Principle Chart

● Reduction Effect of Power Supply to Refrigeration Machine Pumps

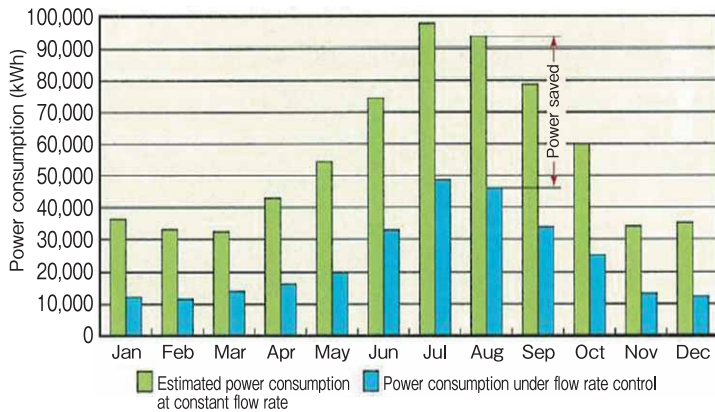

● Effect of Annual Energy Saving

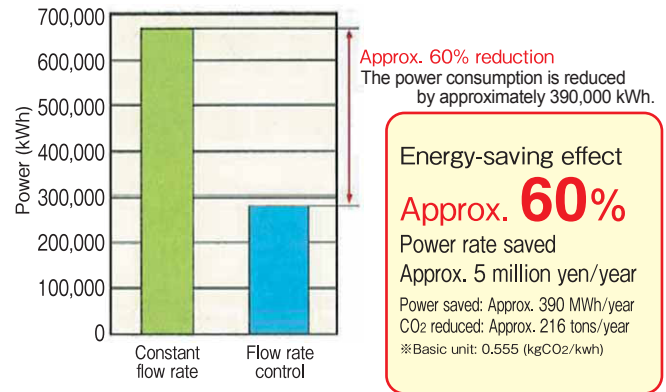

Energy-saving Track Record Graph

Applicable field  
Offices, Hospitals, Commercial Facilities and Buildings, and Industrial Facilities  
such as Semiconductor, Pharmaceutical, and Leather/Fabrics

Water

Energy saving/Energy recovery

Energy storage/Energy creation

New energy

Waste disposal/  
Recycling/  
Resource saving

Air

Soil

Other

## DAI-DAN Co., Ltd.

Technical Development Division, Environmental Technology Section

390 Kitanagai, Miyoshi-machi, Iruma-gun, Saitama 354-0044

● TEL / +81-49-258-1511 ● FAX / +81-49-258-7601 ● E-Mail / tech-info@daidan.co.jp ● http://www.daidan.co.jp

※Note: This publication introduces examples of technologies and products believed useful towards solving environmental and energy issues. In no way does it constitute guarantees concerning their transfer or sale.